

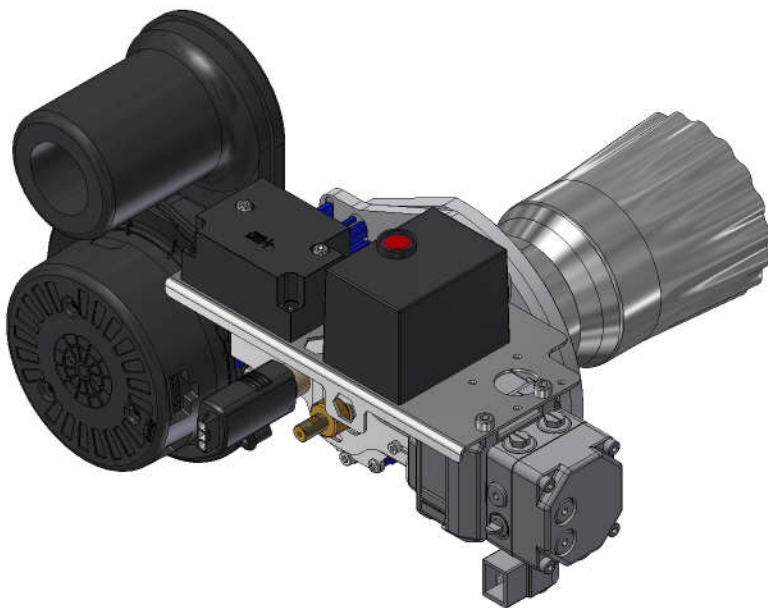

# MODULATING BLUE FLAME OIL BURNER

US Patent 8,882,491 B2

*"Burns blue like a gas flame"<sup>SM</sup>*



- < 10 ppm CO
- < 50 ppm NOx (<40 possible)
- Soot free combustion
- Low noise
- Stable Flame
- Good cold start performance
- High recirculation ratio
- Easy maintenance
- Industry-standardized parts
- True modulation (1:3), not stepped
- Available up to 400,000 BTUh

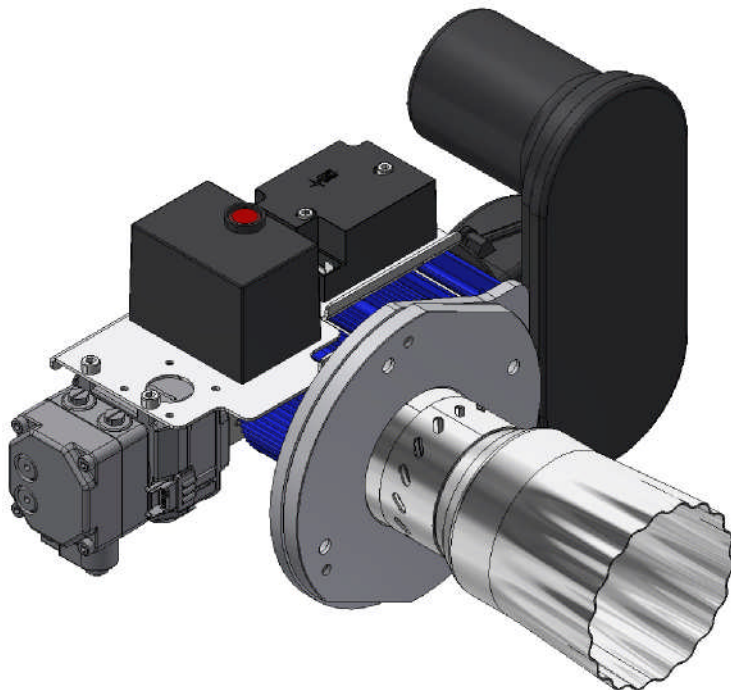

Compact design and clean burn low emissions are a perfect fit for condensing boilers



Fan with PWM-control

Air channel with tangential air flow

Gear pump with PWM controlled permanent magnet motor

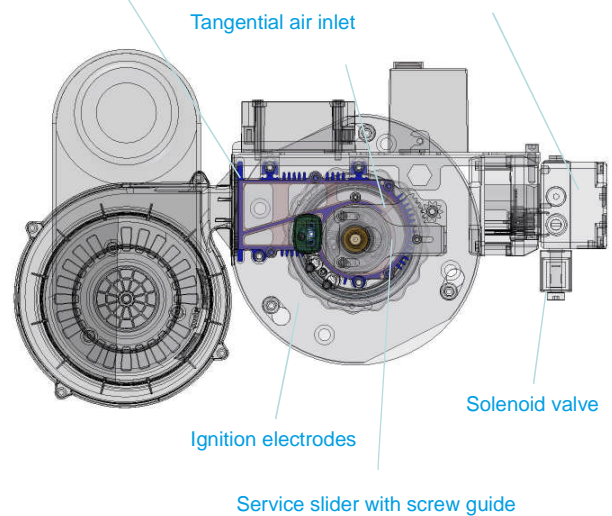
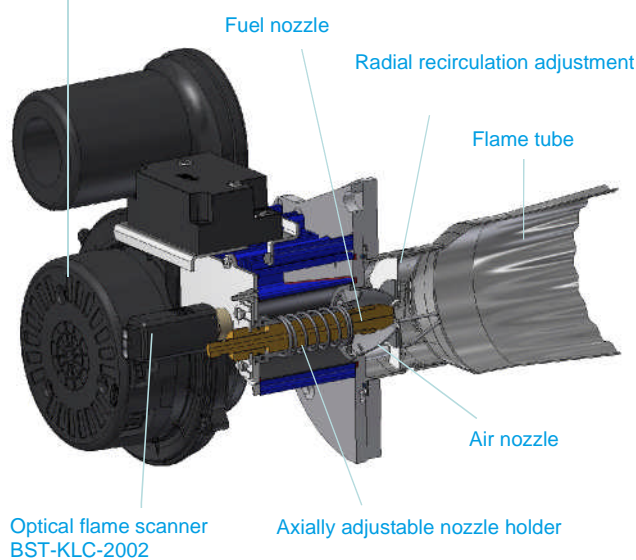

Available with or without the pump, valve, fan/blower, or control. This affords the OEM an opportunity to reduce costs by obtaining these items themselves directly from those parts suppliers.

Made in Germany with high quality materials and workmanship.

Imported and represented in North America by



**IDEAL FLAME LLC** 570 Morningside Drive Bridgewater NJ 08807

908 450 7070 **800 743 1433** fax 908 450 7073 [www.idealflame.com](http://www.idealflame.com)